

Description & Features

- * Sprinkler Gauge
- * Suitable for air and water media
- * Corrosion resistant case
- * Dual scales (psi/kpa, psi/bar, psi/kg/cm²) and single scale (psi)
- * Approved by Factory Mutual (FM) and listed by Underwriter
- * Laboratory (UL)
- * Internal pointer over-travel stop
- * ASME B40.100 compliant



Applications

- * Ideally suited for fire sprinkler systems and fire fighting equipment

Specifications	
Dial	3.5"(93mm),white aluminum with black
Case	Black plastic
Lens	Polycarbonate, threaded
Socket	Brass
Connection	1/4" NPT standard thread
Bourdon Tube	Phosphor bronze
Pointer	Black aluminium
Movement	Brass
Accuracy	±3-2-3% ASME Grade B

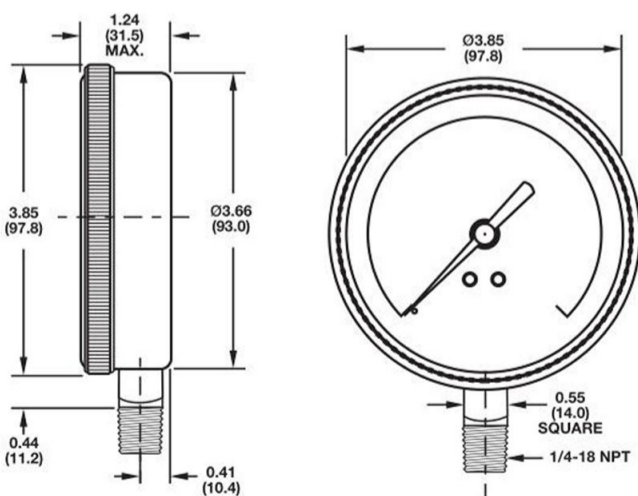

PSG Series Product Code

Product	Air	Water	Air/Water
0/80/retard/250 psi	SG11	/	/
0/300 psi	/	SG22	SG32
0/80/retard/250 psi/kPa	SG13	/	/
0/300 psi/kPa	/	SG24	SG34
0/80/retard/250 psi/bar	SG15	/	/
0/300 psi/bar	/	SG26	SG36
0/80/retard/250 psi/kg/cm ²	SG17	/	/
0/300 psi/kg/cm ²	/	SG28	SG38